



KERKAU

MANUFACTURING



B16.5 Straight Hub Welding Flanges



TABLE OF CONTENTS

Title Page

Table of Contents

Tolerance Page

Dimensions of Class 150 Flanges

Dimensions of Class 300 Flanges

Dimensions of Class 400 Flanges

Dimensions of Class 600 Flanges

Dimensions of Class 900 Flanges

Dimensions of Class 1500 Flanges

Dimensions of Class 2500 Flanges

*NOTE: This book is based on ASME B16.5 2013. For accuracy, some sections have been taken directly from the standard.



FLANGE TOLERANCES

GENERAL NOTE: Dimensions are in inches.

*Outside Diameter of Flange (dimension O)

OD ≤ 12	± 0.060
OD $> 12, \leq 24$	± 0.120
OD > 24	± 0.190

Thickness of Flange (dimension C)

All Sizes

NPS 18 and smaller	+0.120, -zero
NPS 20 and larger	+0.190, -zero

Hub (dimension X)

All Sizes	+0.120, -zero
-----------	---------------

Length Through Hub (dimension Y)

NPS 4 and smaller	± 0.060
NPS 5 to 10, inclusive	+0.060, -0.120
NPS 12 and larger	+0.120, -0.180

Bore (dimension J)

NPS 10 and smaller	± 0.030
NPS 12 to 18, inclusive	± 0.060
NPS 20 and larger	+0.120, -0.060

Facings

*Facing Height

± 0.010

Diameter of raised face (dimension R & K)

Class 150, 300 (0.06 in. raised face)	± 0.030
Class 400 + (0.25 in. raised face)	± 0.020
Ring Type Joint	+0.020, -zero

Facings (continued)

Inside and outside diameter of large and small tongue, groove, male and female

R, S, T, U, W, X, Y & Z	± 0.020
K & L	+0.020, -zero

Ring Joint Facing

Depth (dimension E)

+0.016, -zero

Width (dimension F)

± 0.008

Pitch diameter (dimension P)

± 0.005

Radius at bottom (dimension R)

R ≤ 0.060 +0.030, -zero

R > 0.060 ± 0.030

23 degree angle

$\pm 1/2$ deg.

Drilling and Facing

Diameter of bolt circle

± 0.060

Center-to-center of adjacent bolt holes

± 0.030

Eccentricity between bolt circle and diameter and machined facing diameters

NPS 2 1/2 and smaller ± 0.030

NPS 3 and larger ± 0.060

*Diameter of bolt holes

± 0.020

Note: Tolerances marked with an * are Kerkau tolerances

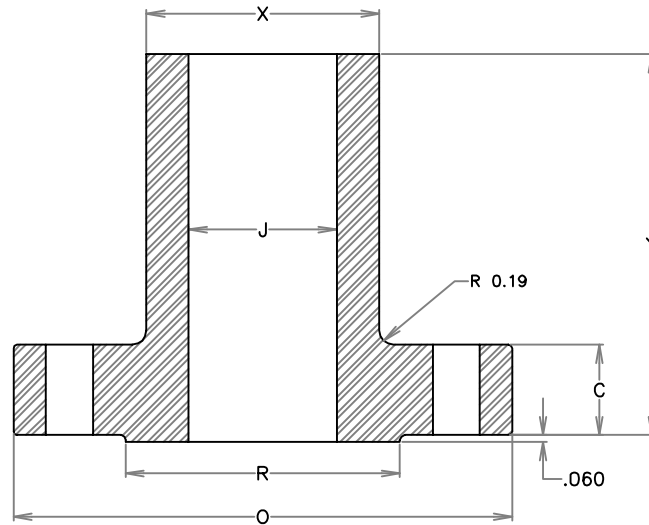

ASME B16.5 CLASS 150 STRAIGHT HUB WELDING FLANGE DIMENSIONS

1	2	3	4	5	6	7	8	9	10
Nominal Size and Bore	Outside Diameter	Minimum Flange Thickness	Diameter of Raised Face	Diameter of Hub at Weld End	Length Through Hub	Drilling			
						Number of Bolt Holes	Diameter of Bolt Holes	Diameter of Bolts	Diameter of Bolt Circle
J	O	C	R	X	Y				
1/2	3.50	0.38	1.38	1.19		4	0.62	1/2	2.38
3/4	3.88	0.44	1.69	1.50		4	0.62	1/2	2.75
1	4.25	0.50	2.00	1.94		4	0.62	1/2	3.12
1 1/4	4.62	0.56	2.50	2.31	S E E	4	0.62	1/2	3.50
1 1/2	5.00	0.62	2.88	2.56		4	0.62	1/2	3.88
2	6.00	0.69	3.62	3.06		4	0.75	5/8	4.75
2 1/2	7.00	0.81	4.12	3.56		4	0.75	5/8	5.50
3	7.50	0.88	5.00	4.25	N O T E	4	0.75	5/8	6.00
3 1/2	8.50	0.88	5.50	4.81		8	0.75	5/8	7.00
4	9.00	0.88	6.19	5.31		8	0.75	5/8	7.50
5	10.00	0.88	7.31	6.44		8	0.88	3/4	8.50
6	11.00	0.94	8.50	7.56	2	8	0.88	3/4	9.50
8	13.50	1.06	10.62	9.69		8	0.88	3/4	11.75
10	16.00	1.12	12.75	12.00		12	1.00	7/8	14.25
12	19.00	1.19	15.00	14.38		12	1.00	7/8	17.00
14	21.00	1.31	16.25	15.75		12	1.12	1	18.75
16	23.50	1.38	18.50	18.00		16	1.12	1	21.25
18	25.00	1.50	21.00	19.88		16	1.25	1 1/8	22.75
20	27.50	1.62	23.00	22.00		20	1.25	1 1/8	25.00
24	32.00	1.81	27.25	26.12		20	1.38	1 1/4	29.50

- All Dimensions shown are in inches.
- Length through Hub dimensions to be specified by purchaser.
- Straight Hub Welding Flanges will be furnished with bore as shown in column 1; other bore sizes may be specified by purchaser.
- Flange facing shall have a finish of 125 μ in. to 250 μ in. roughness, unless otherwise specified.

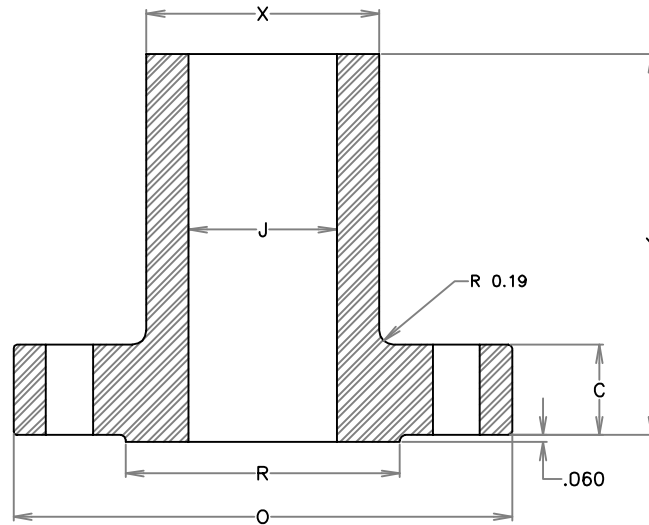

ASME B16.5 CLASS 300 STRAIGHT HUB WELDING FLANGE DIMENSIONS

1 Nominal Size and Bore	2 Outside Diameter	3 Minimum Flange Thickness	4 Diameter of Raised Face	5 Diameter of Hub at Weld End	6 Length Through Hub	7-10 Drilling			
						7 Number of Bolt Holes	8 Diameter of Bolt Holes	9 Diameter of Bolts	10 Diameter of Bolt Circle
J	O	C	R	X	Y				
1/2	3.75	0.50	1.38	1.50		4	0.62	1/2	2.62
3/4	4.62	0.56	1.69	1.88		4	0.75	5/8	3.25
1	4.88	0.62	2.00	2.12		4	0.75	5/8	3.50
1 1/4	5.25	0.69	2.50	2.50	S E E	4	0.75	5/8	3.88
1 1/2	6.12	0.75	2.88	2.75		4	0.88	3/4	4.50
2	6.50	0.81	3.62	3.31	E E	8	0.75	5/8	5.00
2 1/2	7.50	0.94	4.12	3.94		8	0.88	3/4	5.88
3	8.25	1.06	5.00	4.62	N O T E	8	0.88	3/4	6.62
3 1/2	9.00	1.12	5.50	5.25		8	0.88	3/4	7.25
4	10.00	1.19	6.19	5.75	N O T E	8	0.88	3/4	7.88
5	11.00	1.31	7.31	7.00		8	0.88	3/4	9.25
6	12.50	1.38	8.50	8.12	2	12	0.88	3/4	10.62
8	15.00	1.56	10.62	10.25		12	1.00	7/8	13.00
10	17.50	1.81	12.75	12.62		16	1.12	1	15.25
12	20.50	1.94	15.00	14.75		16	1.25	1 1/8	17.75
14	23.00	2.06	16.25	16.75		20	1.25	1 1/8	20.25
16	25.50	2.19	18.50	19.00		20	1.38	1 1/4	22.50
18	28.00	2.31	21.00	21.00		24	1.38	1 1/4	24.75
20	30.50	2.44	23.00	23.12		24	1.38	1 1/4	27.00
24	36.00	2.69	27.25	27.62		24	1.62	1 1/2	32.00

- All Dimensions shown are in inches.
- Length through Hub dimensions to be specified by purchaser.
- Straight Hub Welding Flanges will be furnished with bore as shown in column 1; other bore sizes may be specified by purchaser.
- Flange facing shall have a finish of 125 μ in. to 250 μ in. roughness, unless otherwise specified.

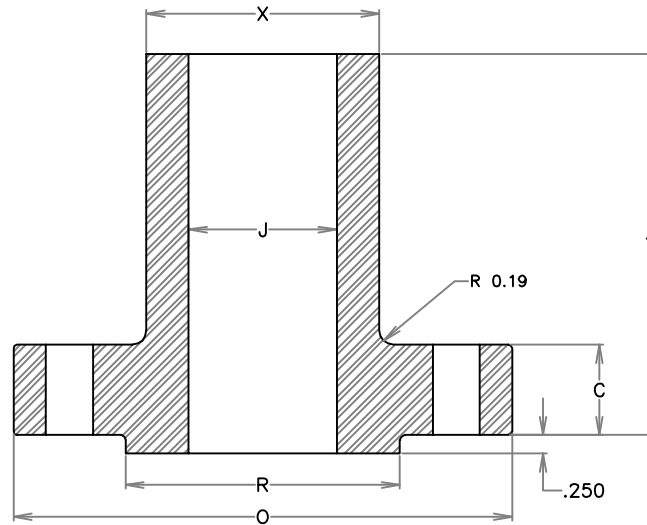

ASME B16.5 CLASS 400 STRAIGHT HUB WELDING FLANGE DIMENSIONS

1 Nominal Size and Bore	2 Outside Diameter	3 Minimum Flange Thickness	4 Diameter of Raised Face	5 Diameter of Hub at Weld End	6 Length Through Hub	7-10 Drilling			
						7 Number of Bolt Holes	8 Diameter of Bolt Holes	9 Diameter of Bolts	10 Diameter of Bolt Circle
J	O	C	R	X	Y				
1/2	3.75	0.56	1.38	1.50	S E E N O T E 2	4	0.62	1/2	2.62
3/4	4.62	0.62	1.69	1.88		4	0.75	5/8	3.25
1	4.88	0.69	2.00	2.12		4	0.75	5/8	3.50
1 1/4	5.25	0.81	2.50	2.50		4	0.75	5/8	3.88
1 1/2	6.12	0.88	2.88	2.75		4	0.88	3/4	4.50
2	6.50	1.00	3.62	3.31		8	0.75	5/8	5.00
2 1/2	7.50	1.12	4.12	3.94		8	0.88	3/4	5.88
3	8.25	1.25	5.00	4.62		8	0.88	3/4	6.62
3 1/2	9.00	1.38	5.50	5.25		8	1.00	7/8	7.25
4	10.00	1.38	6.19	5.75		8	1.00	7/8	7.88
5	11.00	1.50	7.31	7.00		8	1.00	7/8	9.25
6	12.50	1.62	8.50	8.12		12	1.00	7/8	10.62
8	15.00	1.88	10.62	10.25		12	1.12	1	13.00
10	17.50	2.12	12.75	12.62		16	1.25	1 1/8	15.25
12	20.50	2.25	15.00	14.75		16	1.38	1 1/4	17.75
14	23.00	2.38	16.25	16.75		20	1.38	1 1/4	20.25
16	25.50	2.50	18.50	19.00		20	1.50	1 3/8	22.50
18	28.00	2.62	21.00	21.00		24	1.50	1 3/8	24.75
20	30.50	2.75	23.00	23.12		24	1.62	1 1/2	27.00
24	36.00	3.00	27.25	27.62		24	1.88	1 3/4	32.00

1. All Dimensions shown are in inches.
2. Length through Hub dimensions to be specified by purchaser.
3. Straight Hub Welding Flanges will be furnished with bore as shown in column 1; other bore sizes may be specified by purchaser.
4. Flange facing shall have a finish of 125 μ in. to 250 μ in. roughness, unless otherwise specified.

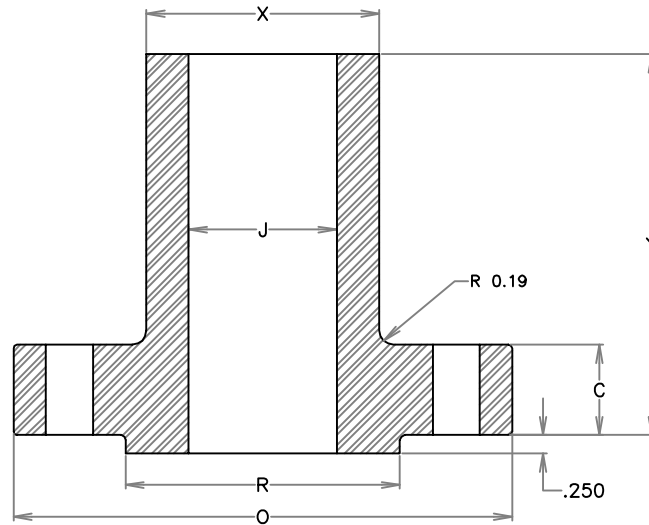

ASME B16.5 CLASS 600 STRAIGHT HUB WELDING FLANGE DIMENSIONS

1 Nominal Size and Bore	2 Outside Diameter	3 Minimum Flange Thickness	4 Diameter of Raised Face	5 Diameter of Hub at Weld End	6 Length Through Hub	7 Drilling			
						7 Number of Bolt Holes	8 Diameter of Bolt Holes	9 Diameter of Bolts	10 Diameter of Bolt Circle
J	O	C	R	X	Y				
1/2	3.75	0.56	1.38	1.50	S E E N O T E 2	4	0.62	1/2	2.62
3/4	4.62	0.62	1.69	1.88		4	0.75	5/8	3.25
1	4.88	0.69	2.00	2.12		4	0.75	5/8	3.50
1 1/4	5.25	0.81	2.50	2.50		4	0.75	5/8	3.88
1 1/2	6.12	0.88	2.88	2.75		4	0.88	3/4	4.50
2	6.50	1.00	3.62	3.31		8	0.75	5/8	5.00
2 1/2	7.50	1.12	4.12	3.94		8	0.88	3/4	5.88
3	8.25	1.25	5.00	4.62		8	0.88	3/4	6.62
3 1/2	9.00	1.38	5.50	5.25		8	1.00	7/8	7.25
4	10.75	1.50	6.19	6.00		8	1.00	7/8	8.50
5	13.00	1.75	7.31	7.44		8	1.12	1	10.50
6	14.00	1.88	8.50	8.75		12	1.12	1	11.50
8	16.50	2.19	10.62	10.75		12	1.25	1 1/8	13.75
10	20.00	2.50	12.75	13.50		16	1.38	1 1/4	17.00
12	22.00	2.62	15.00	15.75		20	1.38	1 1/4	19.25
14	23.75	2.75	16.25	17.00		20	1.50	1 3/8	20.75
16	27.00	3.00	18.50	19.50		20	1.62	1 1/2	23.75
18	29.25	3.25	21.00	21.50		20	1.75	1 5/8	25.75
20	32.00	3.50	23.00	24.00		24	1.75	1 5/8	28.50
24	37.00	4.00	27.25	28.25		24	2.00	1 7/8	33.00

- All Dimensions shown are in inches.
- Length through Hub dimensions to be specified by purchaser.
- Straight Hub Welding Flanges will be furnished with bore as shown in column 1; other bore sizes may be specified by purchaser.
- Flange facing shall have a finish of 125 μ in. to 250 μ in. roughness, unless otherwise specified.

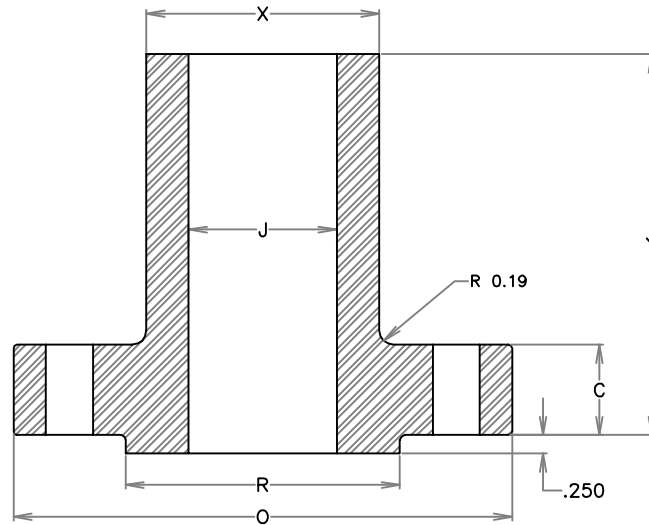

ASME B16.5 CLASS 900 STRAIGHT HUB WELDING FLANGE DIMENSIONS

1 Nominal Size and Bore	2 Outside Diameter	3 Minimum Flange Thickness	4 Diameter of Raised Face	5 Diameter of Hub at Weld End	6 Length Through Hub	7 Drilling				
						7 Number of Bolt Holes	8 Diameter of Bolt Holes	9 Diameter of Bolts	10 Diameter of Bolt Circle	
J	O	C	R	X	Y					
1/2	4.75	0.88	1.38	1.50	S E E	4	0.88	3/4	3.25	
3/4	5.12	1.00	1.69	1.75		4	0.88	3/4	3.50	
1	5.88	1.12	2.00	2.06		4	1.00	7/8	4.00	
1 1/4	6.25	1.12	2.50	2.50		4	1.00	7/8	4.38	
1 1/2	7.00	1.25	2.88	2.75		4	1.12	1	4.88	
2	8.50	1.50	3.62	4.12		8	1.00	7/8	6.50	
2 1/2	9.62	1.62	4.12	4.88		8	1.12	1	7.50	
3	9.50	1.50	5.00	5.00		8	1.00	7/8	7.50	
3 1/2	---	---	---	---		---	---	---	---	---
4	11.50	1.75	6.19	6.25		N O T E 2	8	1.25	1 1/8	9.25
5	13.75	2.00	7.31	7.50	8		1.38	1 1/4	11.00	
6	15.00	2.19	8.50	9.25	12		1.25	1 1/8	12.50	
8	18.50	2.50	10.62	11.75	12		1.50	1 3/8	15.50	
10	21.50	2.75	12.75	14.50	16		1.50	1 3/8	18.50	
12	24.00	3.12	15.00	16.50	20		1.50	1 3/8	21.00	
14	25.25	3.38	16.25	17.75	20		1.62	1 1/2	22.00	
16	27.75	3.50	18.50	20.00	20		1.75	1 5/8	24.25	
18	31.00	4.00	21.00	22.25	20		2.00	1 7/8	27.00	
20	33.75	4.25	23.00	24.50	20		2.12	2	29.50	
24	41.00	5.50	27.25	29.50	20	2.62	2 1/2	35.50		

- All Dimensions shown are in inches.
- Length through Hub dimensions to be specified by purchaser.
- Straight Hub Welding Flanges will be furnished with bore as shown in column 1; other bore sizes may be specified by purchaser.
- Flange facing shall have a finish of 125 μ in. to 250 μ in. roughness, unless otherwise specified.

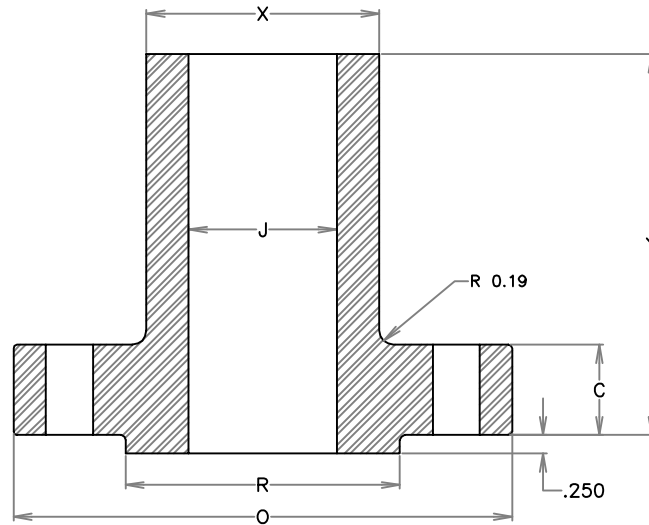

ASME B16.5 CLASS 1500 STRAIGHT HUB WELDING FLANGE DIMENSIONS

1 Nominal Size and Bore	2 Outside Diameter	3 Minimum Flange Thickness	4 Diameter of Raised Face	5 Diameter of Hub at Weld End	6 Length Through Hub	7 Drilling			
						7 Number of Bolt Holes	8 Diameter of Bolt Holes	9 Diameter of Bolts	10 Diameter of Bolt Circle
J	O	C	R	X	Y				
1/2	4.75	0.88	1.38	1.50	S E E	4	0.875	3/4	3.25
3/4	5.12	1.00	1.69	1.75		4	0.875	3/4	3.50
1	5.88	1.12	2.00	2.06		4	1.000	7/8	4.00
1 1/4	6.25	1.12	2.50	2.50		4	1.000	7/8	4.38
1 1/2	7.00	1.25	2.88	2.75		4	1.125	1	4.88
2	8.50	1.50	3.62	4.12		8	1.000	7/8	6.50
2 1/2	9.62	1.62	4.12	4.88		8	1.125	1	7.50
3	10.50	1.88	5.00	5.25		8	1.250	1 1/8	8.00
3 1/2	---	---	---	---		---	---	---	---
4	12.25	2.12	6.19	6.38		N O T E 2	8	1.375	1 1/4
5	14.75	2.88	7.31	7.75	8		1.625	1 1/2	11.50
6	15.50	3.25	8.50	9.00	12		1.500	1 3/8	12.50
8	19.00	3.62	10.62	11.50	12		1.750	1 5/8	15.50
10	23.00	4.25	12.75	14.50	12		2.000	1 7/8	19.00
12	26.50	4.88	15.00	17.75	16		2.125	2	22.50
14	29.50	5.25	16.25	19.50	16		2.375	2 1/4	25.00
16	32.50	5.75	18.50	21.75	16		2.625	2 1/2	27.75
18	36.00	6.38	21.00	23.50	16		2.875	2 3/4	30.50
20	38.75	7.00	23.00	25.25	16		3.125	3	32.75
24	46.00	8.00	27.25	30.00	16	3.625	3 1/2	39.00	

- All Dimensions shown are in inches.
- Length through Hub dimensions to be specified by purchaser.
- Straight Hub Welding Flanges will be furnished with bore as shown in column 1; other bore sizes may be specified by purchaser.
- Flange facing shall have a finish of 125 μ in. to 250 μ in. roughness, unless otherwise specified.

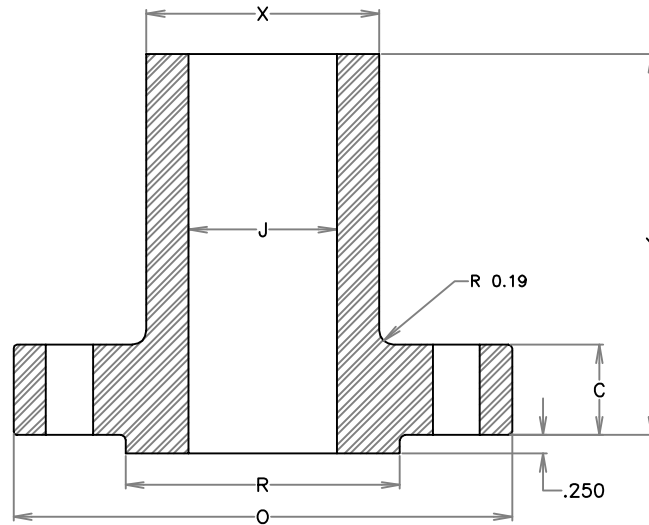

ASME B16.5 CLASS 2500 STRAIGHT HUB WELDING FLANGE DIMENSIONS

1	2	3	4	5	6	7	8	9	10
Nominal Size and Bore	Outside Diameter	Minimum Flange Thickness	Diameter of Raised Face	Diameter of Hub at Weld End	Length Through Hub	Drilling			
						Number of Bolt Holes	Diameter of Bolt Holes	Diameter of Bolts	Diameter of Bolt Circle
J	O	C	R	X	Y				
1/2	5.25	1.19	1.38	1.69		4	0.88	3/4	3.50
3/4	5.50	1.25	1.69	2.00		4	0.88	3/4	3.75
1	6.25	1.38	2.00	2.25		4	1.00	7/8	4.25
1 1/4	7.25	1.50	2.50	2.88	S E E	4	1.12	1	5.12
1 1/2	8.00	1.75	2.88	3.12		4	1.25	1 1/8	5.75
2	9.25	2.00	3.62	3.75		8	1.12	1	6.75
2 1/2	10.50	2.25	4.12	4.50	E E E	8	1.25	1 1/8	7.75
3	12.00	2.62	5.00	5.25		8	1.38	1 1/4	9.00
3 1/2	---	---	---	---		---	---	---	---
4	14.00	3.00	6.19	6.50	N O T E	8	1.62	1 1/2	10.75
5	16.50	3.62	7.31	8.00		8	1.88	1 3/4	12.75
6	19.00	4.25	8.50	9.25		8	2.12	2	14.50
8	21.75	5.00	10.62	12.00	E E E	12	2.12	2	17.25
10	26.50	6.50	12.75	14.75		12	2.62	2 1/2	21.25
12	30.00	7.25	15.00	17.38		12	2.88	2 3/4	24.38
14	---	---	---	---	2	---	---	---	---
16	---	---	---	---		---	---	---	---
18	---	---	---	---		---	---	---	---
20	---	---	---	---		---	---	---	---
24	---	---	---	---		---	---	---	---

- All Dimensions shown are in inches.
- Length through Hub dimensions to be specified by purchaser.
- Straight Hub Welding Flanges will be furnished with bore as shown in column 1; other bore sizes may be specified by purchaser.
- Flange facing shall have a finish of 125 μ in. to 250 μ in. roughness, unless otherwise specified.